

NOVIN HYDRAULIC

HYDRAULIC CYLINDERS



WE SUPPLY QUALITY

NOVIN HYDRAULIC

شرکت نوین هیدرولیک از سال ۱۳۸۳ اقدام به تولید انواع سیلندره‌های هیدرولیک نموده است و در طی این مدت با بهره‌گیری از کارشناسان مجرب داخلی و خارجی و با استفاده از تکنولوژی و ماشین‌آلات مدرن موفق به تولید انواع سیلندره‌های هیدرولیک جهت صنایع نفت - گاز - پتروشیمی - فولاد - خودروسازی - ماشین‌آلات راهسازی و خدمات شهری صنایع ماشین‌سازی و قالب‌سازی و جیگ و فیکسچرها و سایر صنایع گردیده است.

این شرکت قادر است انواع سیلندره‌های هیدرولیک از قطر ۲۰ میلیمتر تا ۵۰۰ میلیمتر و طول کورس تا ۷ متر را تولید نماید. محدوده فشار سیلندره‌های تولید شده توسط این شرکت ۱۶۰ بار می‌باشد و بر اساس نیاز مشتری تا فشار ۴۰۰ بار قابل تحویل می‌باشد. این شرکت همچنین قادر است انواع سیلندره‌های هیدرولیک دو طرفه و یک طرفه سیلندره‌های دوسر شافت - سیلندره‌های برگشت فنر سیلندره‌های هیدروپنوماتیک و انواع مختلف سیلندره‌های غیر استاندارد و ترکیبی و خصوصاً سیلندره‌های تلسکوپی را بر اساس سفارش مشتری طراحی و تولید نماید. بخش دیگری از فعالیت‌های این شرکت شامل ساخت انواع جک‌های هیدرولیک جهت ساخت بالابرها و آسانسورها می‌باشد که در دو نوع تلسکوپی و معمولی به همراه یونیت‌های هیدرولیک معمولی و شناور در روغن قابل ارائه می‌باشد. ما مفتخریم تا با ارائه خدمات هرچه بهتر به مشتریان گامی بلند در جهت پیشبرد صنعت هیدرولیک کشور برداریم.

Since 2004 Novin Hydraulic Company has attempt to produce all kinds of hydraulic cylinders. During this period, taking advantage of internal and external experts and the use of modern technology and machinery has been able to produce all kinds of hydraulic cylinders for oil - gas - petrochemical, steel, automotive, road construction machinery and municipal services - machine-building industry and molding and Jig and fixtures and other industries. This company is able to produce hydraulic cylinders from 20 mm to 500 mm diameter and up to 7 meters length for Course.

The pressure range for cylinders produced by this company is 160 bar and according to customer needs is deliverable up to pressure of 400 bar. This company according to customer's order is also able to design and produce bilateral and unilateral hydraulic cylinders - double shaft cylinders - spring return cylinders - hydropneumatic cylinders and various types of non-standard and combined cylinders and especially telescopic cylinders. Another part of the activities of this company includes the manufacture of various types of hydraulic jacks for construction of lifts and elevators that are available in both normal and telescopic with conventional and floating in oil hydraulic units. We are proud to announce that we hope that by offering even better service to our customers be able to take a big step in advancing hydraulic industry of our country.

NOVIN HYDRAULIC

TYPE : NHA

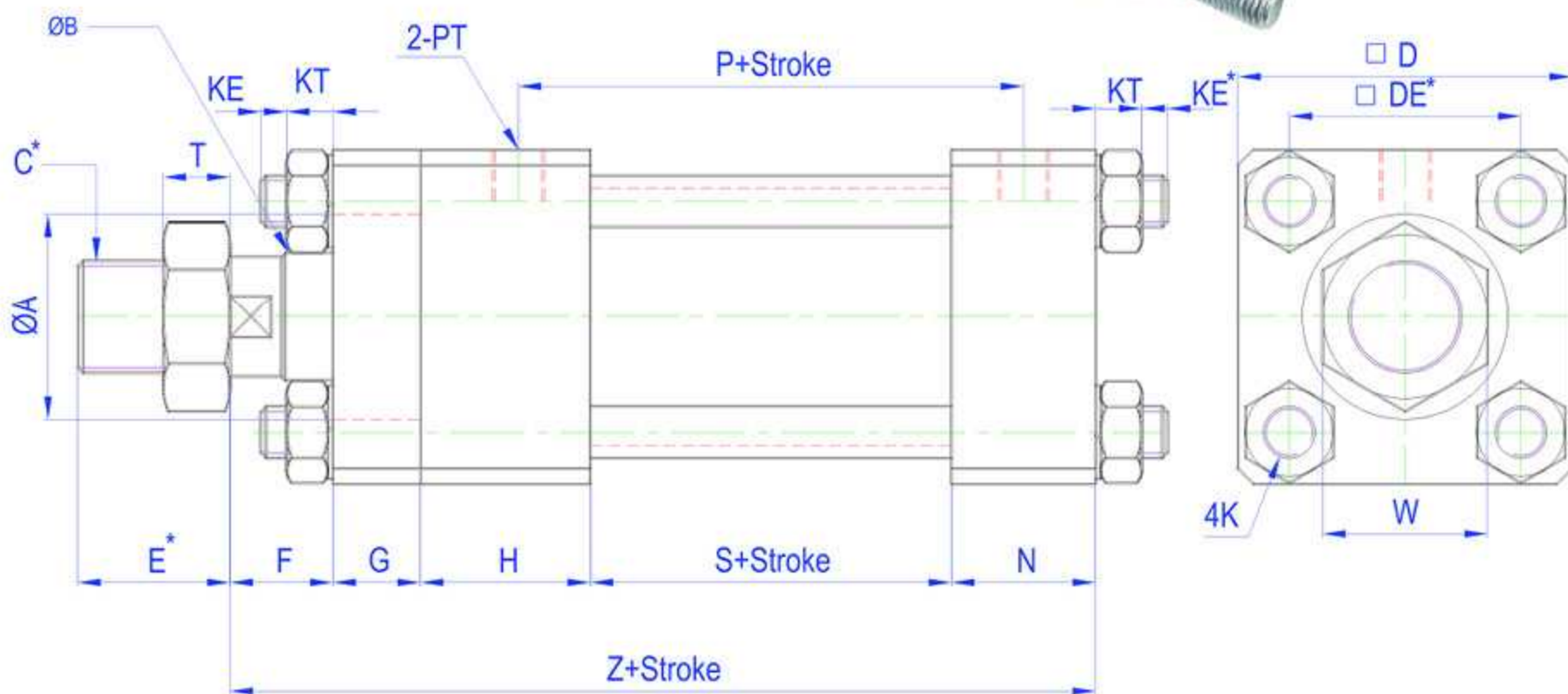

SIZE BORE	ØA	ØB	C*	□D	□DE*	E*	F*	G	H	N	P	PT	K	KE*	KT	S	T	W	Z
Ø40	40	25	M22XP1.5	65	45	40	20	17	33	28	76	3/8	M10XP1.25	10	10.5	50	13	32	148
Ø50	50	30	M26XP1.5	80	56	40	20	17	38	30	85	3/8	M12XP1.5	10	13	55	13	35	160
Ø63	50	35	M30XP1.5	90	62	45	20	17	38	30	85	3/8	M14XP1.5	10	14.5	55	13	41	160
Ø80	60	40	M30XP1.5	110	80	45	20	20	38	35	107	1/2	M16XP1.5	10	17	75	13	41	188
Ø100	80	50	M40XP2	131	95	55	25	20	41	37	123.5	1/2	M18XP1.5	10	19.5	90	15	55	213
Ø125	90	60	M50XP2	162	122	70	35	30	57	47	143	3/4	M22XP1.5	10	23.5	100	15	65	269
Ø150	110	80	M70XP2	195	144	80	35	30	60	50	135	3/4	1-8UNC	15	31	90	20	90	265
Ø180	135	100	M90XP2	235	175	100	35	40	65	55	172	1	1,1/4-8UNC	20	39	120	20	110	315
Ø200	135	100	M90XP2	262	193	100	40	40	65	60	175	1	1,1/4-8UNC	20	39	120	20	110	325

* The above parameters can be adjusted by special order

* پارامترهای فوق با سفارش خاص قابل تغییر می باشد.

NOVIN HYDRAULIC

TYPE : NHB

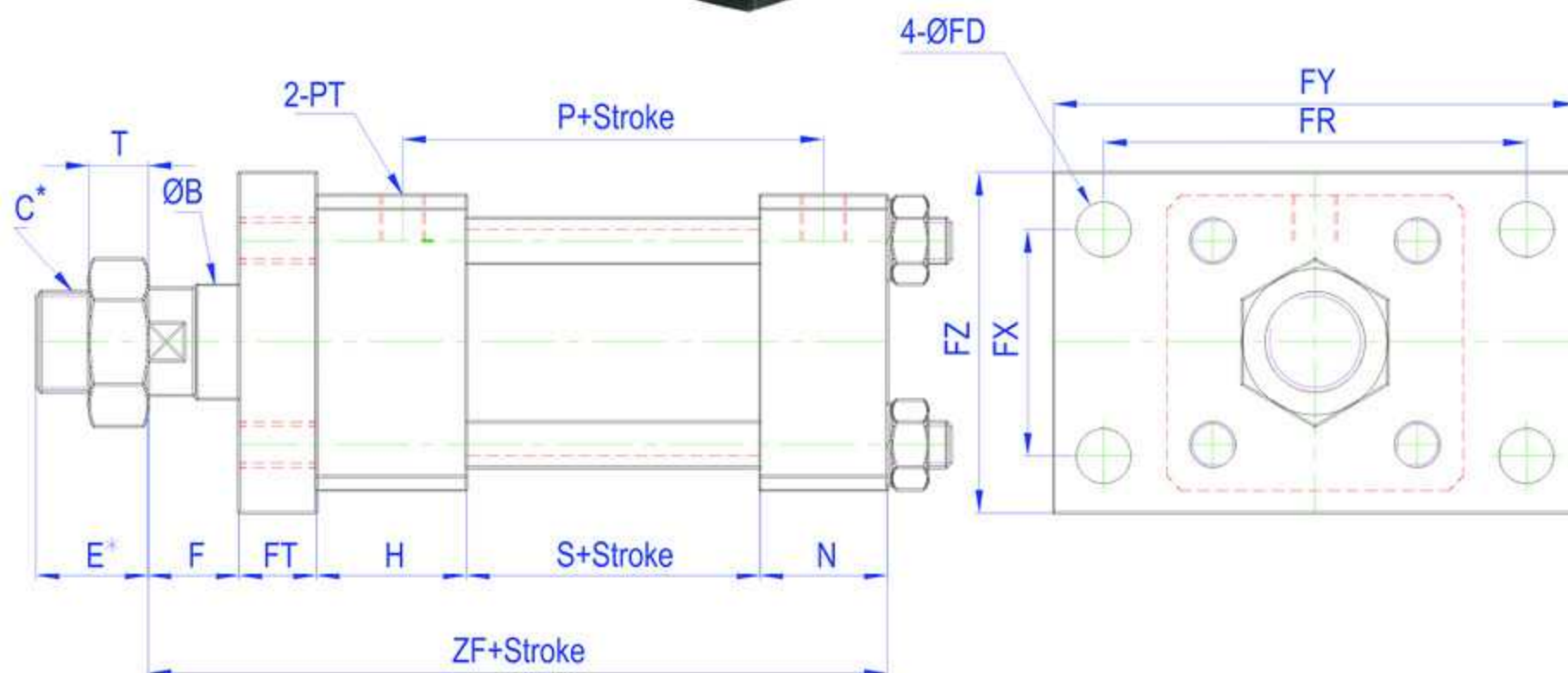

SIZE BORE	ØB	C*	E*	F*	G	H	N	P	PT	S	T	ZF	ØFD	FT	FR	FX	FY	FZ
Ø40	25	M22XP1.5	40	20	17	33	28	76	3/8	50	13	148	12	17	93	50	115	75
Ø50	30	M26XP1.5	40	20	17	38	30	85	3/8	55	13	160	14	17	110	56	150	85
Ø63	35	M30XP1.5	45	20	17	38	30	85	3/8	55	13	160	14	17	126	68	155	95
Ø80	40	M30XP1.5	45	20	20	38	35	107	1/2	75	13	188	18	20	152	75	190	120
Ø100	50	M40XP2	55	25	20	41	37	123.5	1/2	90	15	213	20	20	180	100	220	140
Ø125	60	M50XP2	70	35	30	57	47	143	3/4	100	15	269	24	30	222	122	280	170
Ø150	80	M70XP2	80	35	30	60	50	135	3/4	90	20	265	28	30	260	155	310	206
Ø180	100	M90XP2	100	35	40	65	55	172	1	120	20	315	35	40	315	188	375	250
Ø200	100	M90XP2	100	40	40	65	60	175	1	120	20	325	35	40	355	207	425	272

* The above parameters can be adjusted by special order

* پارامترهای فوق با سفارش خاص قابل تغییر می باشد.

NOVIN HYDRAULIC

TYPE : NHC

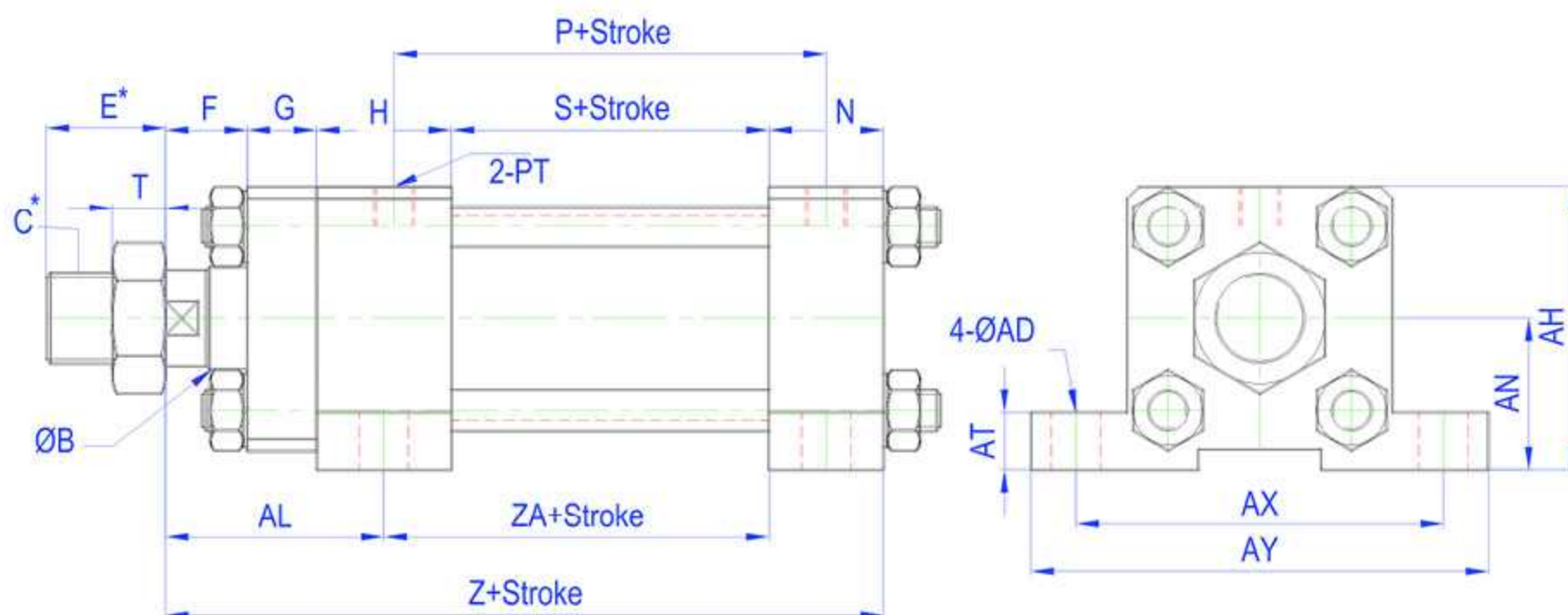

SIZE BORE	ØB	C*	E*	F*	G	H	N	AH	AL	AN	P	PT	S	T	ZA	Z	ØAD	AT	AX	AY
Ø40	25	M22XP1.5	40	20	17	33	28	69.5	53.5	37	76	3/8	50	13	80.5	148	12	14	90	112
Ø50	30	M26XP1.5	40	20	17	38	30	85	56	45	85	3/8	55	13	89	160	14	17	115	140
Ø63	35	M30XP1.5	45	20	17	38	30	95	56	50	85	3/8	55	13	89	160	14	19	128	156
Ø80	40	M30XP1.5	45	20	20	38	35	115	59	60	107	1/2	75	13	111.5	188	18	25	152	184
Ø100	50	M40XP2	55	25	20	41	37	135.5	65.5	70	123.5	1/2	90	15	129	213	21	27	178	210
Ø125	60	M50XP2	70	35	30	57	47	171	93.5	90	143	3/4	100	15	152	269	24	30	230	280
Ø150	80	M70XP2	80	35	30	60	50	208	95	113	135	3/4	90	20	145	265	28	35	270	325
Ø180	100	M90XP2	100	35	40	65	55	260.5	107.5	143	172	1	120	20	180	315	35	45	330	395
Ø200	100	M90XP2	100	40	40	65	60	292	112.5	161	175	1	120	20	182.5	325	35	50	360	430

* The above parameters can be adjusted by special order

* پارامترهای فوق با سفارش خاص قابل تغییر می باشد.

NOVIN HYDRAULIC

TYPE : NHD

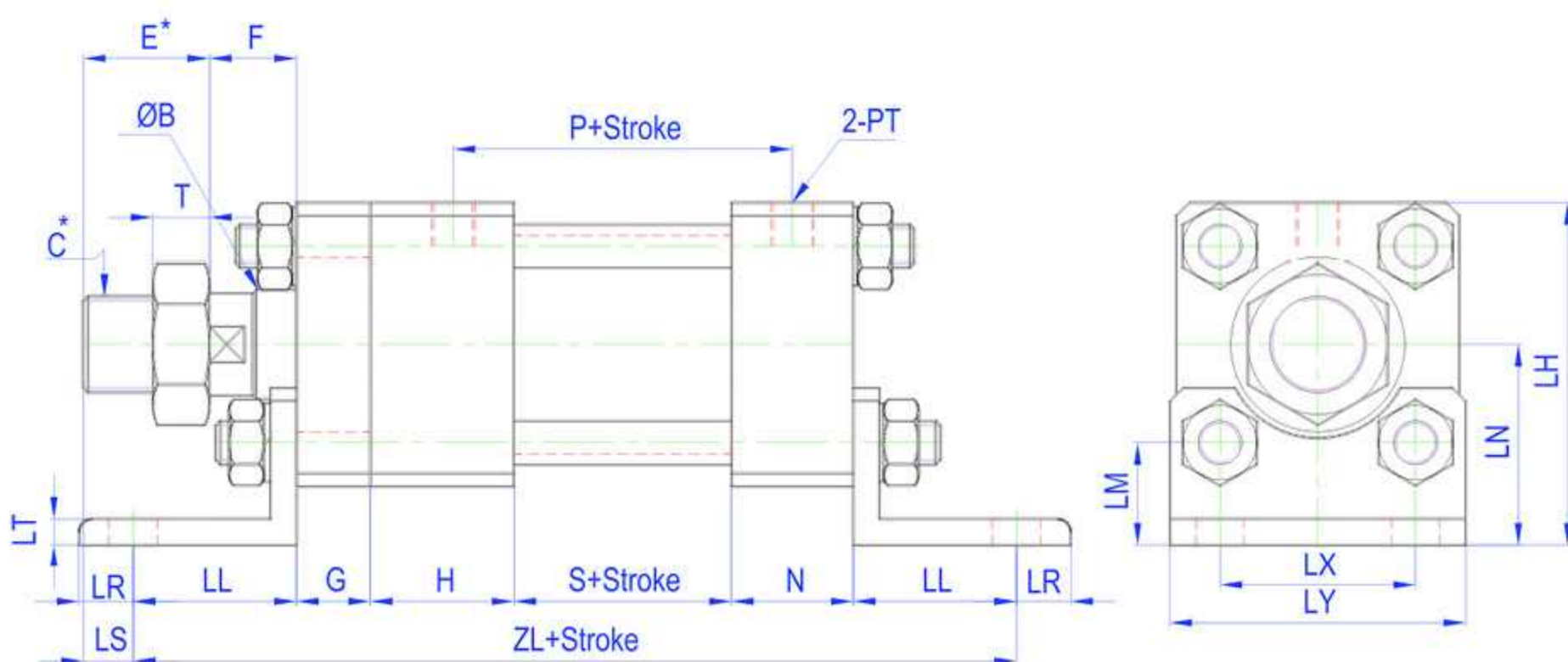

SIZE BORE	ØB	C*	E*	F*	G	H	N	LH	LN	LS	P	PT	S	T	ZL	ØLD	LL	LM	LR	LT	LX	LY
Ø40	25	M22XP1.5	40	20	17	33	28	78.5	46	22.5	76	3/8	50	13	203	11	37.5	23.5	12.5	6	45	68
Ø50	30	M26XP1.5	40	20	17	38	30	94	54	18	85	3/8	55	13	224	14	42	26	22	8	56	85
Ø63	35	M30XP1.5	45	20	17	38	30	102	57	21	85	3/8	55	13	228	16	44	26	22	8	62	95
Ø80	40	M30XP1.5	45	20	20	38	35	131	76	2	107	1/2	75	13	294	18	63	36	27	13	80	120
Ø100	50	M40XP2	55	25	20	41	37	158.5	93	14	123.5	1/2	90	15	320	20	66	45.5	24	15	100	140
Ø125	60	M50XP2	70	35	30	57	47	195	114	25	143	3/4	100	15	394	24	80	53	30	15	122	169
Ø150	80	M70XP2	80	35	30	60	50	220	125	35	135	3/4	90	20	390	28	80	53	30	20	144	200
Ø180	100	M90XP2	100	35	40	65	55	267.5	150	45	172	1	120	20	460	35	90	62.5	40	20	175	240
Ø200	100	M90XP2	100	40	40	65	60	301	170	45	175	1	120	20	475	35	95	73.5	40	25	193	265

* The above parameters can be adjusted by special order

* پارامترهای فوق با سفارش خاص قابل تغییر می باشد.

NOVIN HYDRAULIC

TYPE : NHE

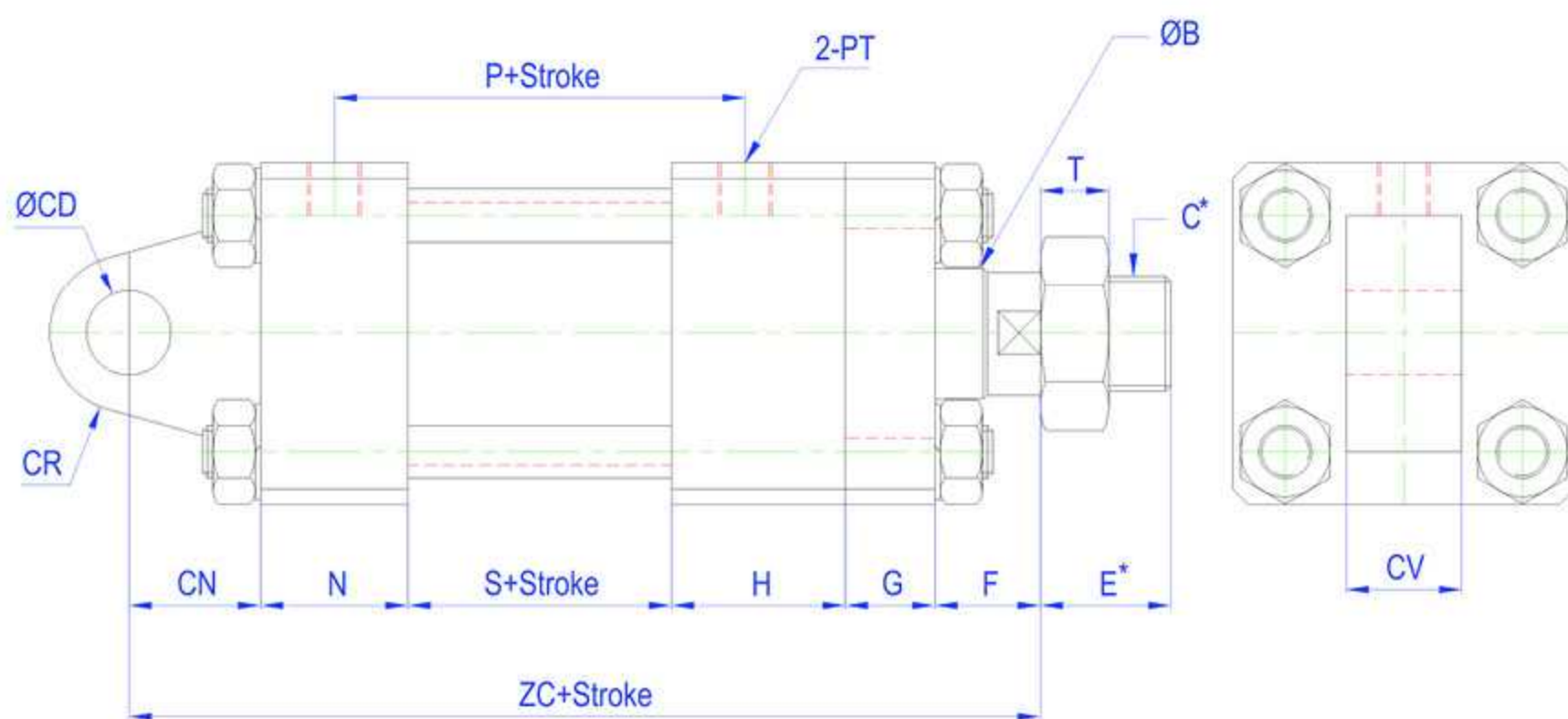

SIZE BORE	ØB	C*	E*	F*	G	H	N	P	PT	S	T	ZC	ØCD	CN	CR	CV
Ø40	25	M22XP1.5	40	20	17	33	28	76	3/8	50	13	173	16	25	15	22
Ø50	30	M26XP1.5	40	20	17	38	30	85	3/8	55	13	195	20	35	20	22
Ø63	35	M30XP1.5	45	20	17	38	30	85	3/8	55	13	205	25	45	25	30
Ø80	40	M30XP1.5	45	20	20	38	35	107	1/2	75	13	238	30	50	30	35
Ø100	50	M40XP2	55	25	20	41	37	123.5	1/2	90	15	273	35	60	35	40
Ø125	60	M50XP2	70	35	30	57	47	143	3/4	100	15	339	50	70	50	55
Ø150	80	M70XP2	80	35	30	60	50	135	3/4	90	20	345	60	80	60	60
Ø180	100	M90XP2	100	35	40	65	55	172	1	120	20	415	80	100	80	80
Ø200	100	M90XP2	100	40	40	65	60	175	1	120	20	435	90	110	90	90

* The above parameters can be adjusted by special order

* پارامترهای فوق با سفارش خاص قابل تغییر می باشد.

NOVIN HYDRAULIC

TYPE : NHF

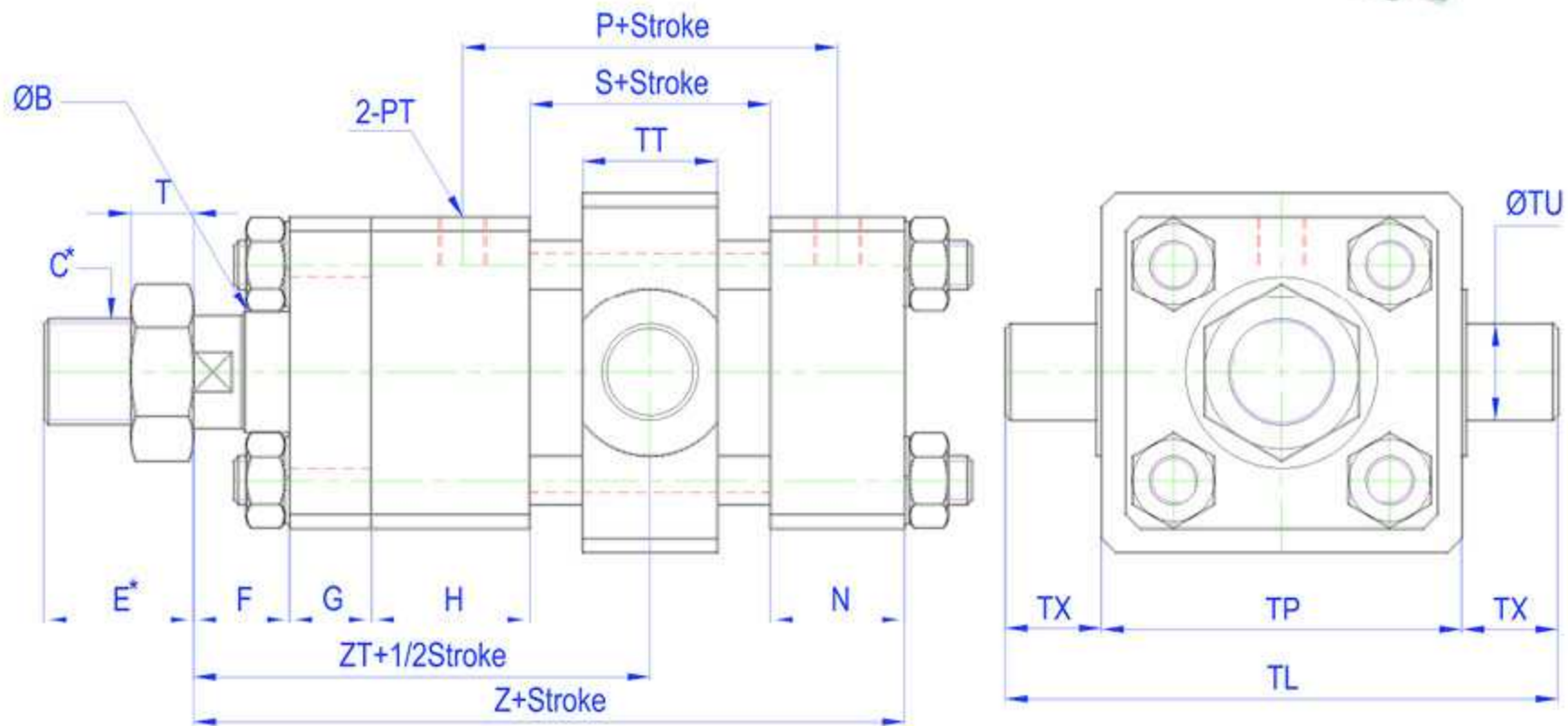

SIZE BORE	ØB	C*	E*	F*	G	H	N	P	PT	S	T	Z	ZT	ØTU	TL	TP	TT	TX
Ø40	25	M22XP1.5	40	20	17	33	28	76	3/8	50	13	148	95	20	115	75	28	20
Ø50	30	M26XP1.5	40	20	17	38	30	85	3/8	55	13	160	102.5	25	140	90	33	25
Ø63	35	M30XP1.5	45	20	17	38	30	85	3/8	55	13	160	102.5	32	166	102	40	32
Ø80	40	M30XP1.5	45	20	20	38	35	107	1/2	75	13	188	115.5	32	184	120	43	32
Ø100	50	M40XP2	55	25	20	41	37	123.5	1/2	90	15	213	131	40	220	140	53	40
Ø125	60	M50XP2	70	35	30	57	47	143	3/4	100	15	269	172	50	275	175	58	50
Ø150	80	M70XP2	80	35	30	60	50	135	3/4	90	20	265	170	60	326	206	73	60
Ø180	100	M90XP2	100	35	40	65	55	172	1	120	20	315	200	80	403	243	98	80
Ø200	100	M90XP2	100	40	40	65	60	175	1	120	20	325	205	90	452	272	108	90

* The above parameters can be adjusted by special order

* پارامترهای فوق با سفارش خاص قابل تغییر می باشد.

NOVIN HYDRAULIC

TYPE : NHK

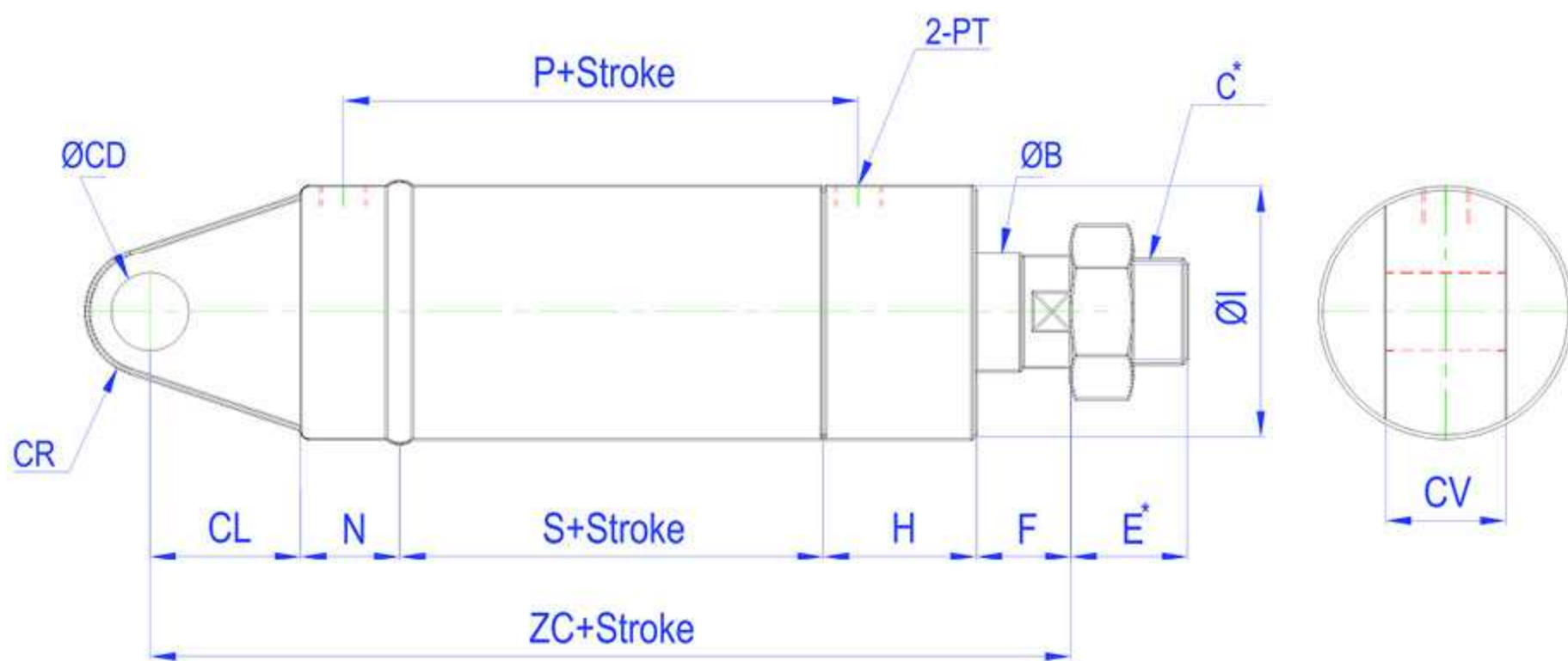

SIZE	ØB	C*	E*	F*	H	ØI	N	P	PT	S	ZC	ØCD	CL	CR	CV
BORE Ø40	25	M22X1.5	40	17	50	50	25	86	3/8	61	178	16	25	18	25

* The above parameters can be adjusted by special order

* پارامترهای فوق با سفارش خاص قابل تغییر می باشد.

NOVIN HYDRAULIC

TYPE : NHL

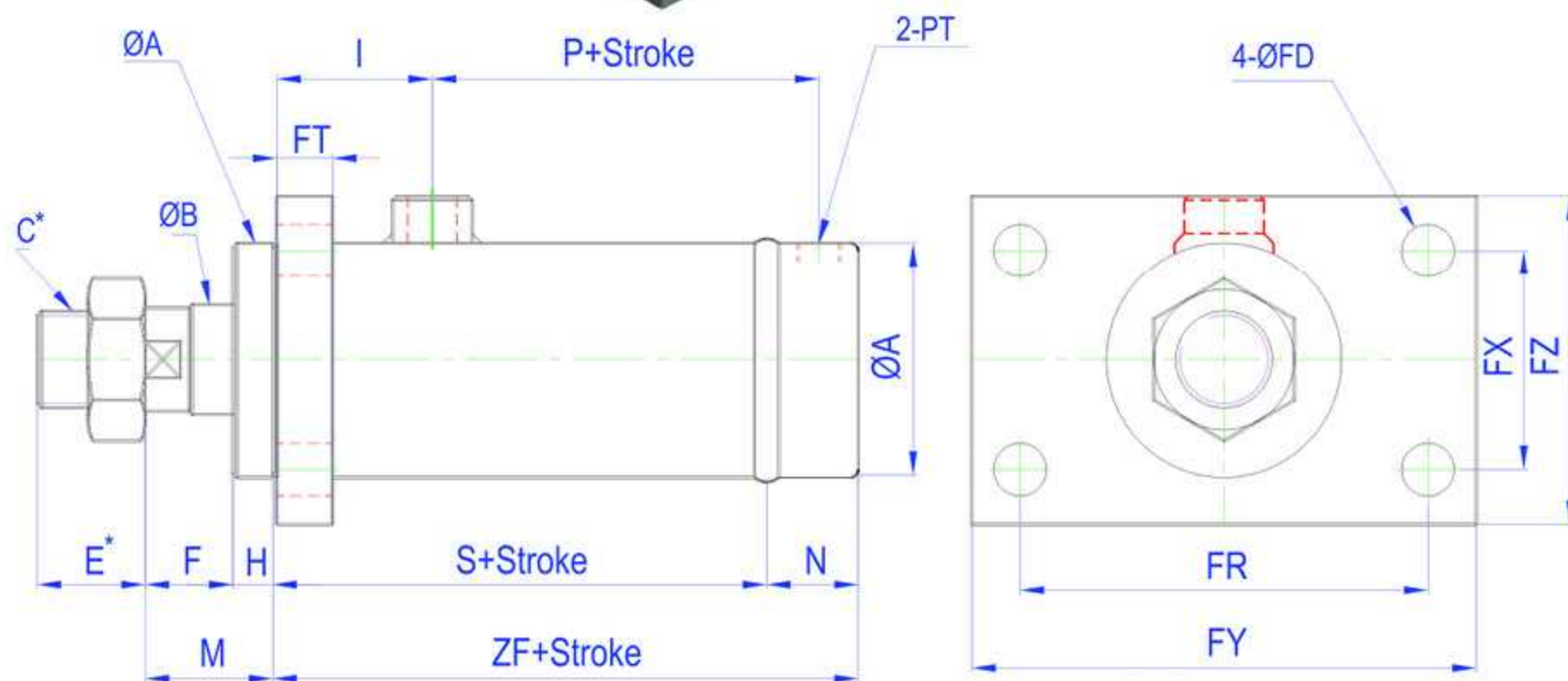

SIZE BORE	ØA	ØB	C*	E*	F*	H	I	M	N	P	PT	S	ZF	ØFD	FT	FR	FX	FY	FZ
Ø50	60	35	M30X1.5	40	20	10	56	30	30	71	3/8	110	140	14	17	110	56	150	85
Ø63	73	40	M30X1.5	45	25	10	56	35	35	79	3/8	115	150	14	17	126	68	155	95
Ø80	95	50	M40X2	55	25	15	64	40	40	83	3/8	125	165	18	20	152	75	190	120
Ø100	115	60	M50X2	70	25	20	78	45	40	94	1/2	150	190	20	20	180	100	220	140
Ø125	140	80	M70X2	80	35	20	78	55	50	109	1/2	160	210	24	30	222	122	280	170

* The above parameters can be adjusted by special order

* پارامترهای فوق با سفارش خاص قابل تغییر می باشد.

NOVIN HYDRAULIC

TYPE : NHM

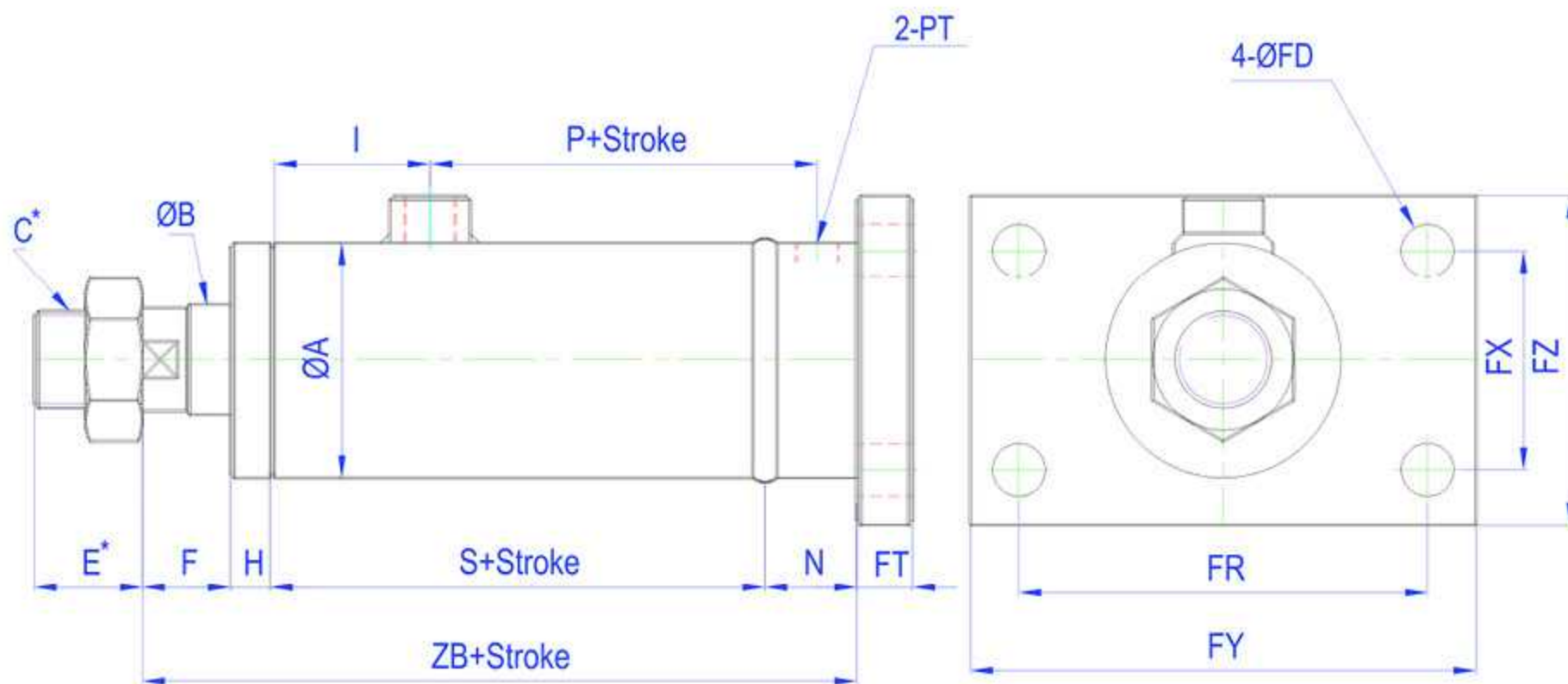

SIZE BORE	ØA	ØB	C*	E*	F*	H	I	N	P	PT	S	ZB	ØFD	FT	FR	FX	FY	FZ
Ø50	60	35	M30X1.5	40	20	10	56	30	71	3/8	110	187	14	17	110	56	150	85
Ø63	73	40	M30X1.5	45	25	10	56	35	79	3/8	115	202	14	17	126	68	155	95
Ø80	95	50	M40X2	55	25	15	64	40	83	3/8	125	225	18	20	152	75	190	120
Ø100	115	60	M50X2	70	25	20	78	40	94	1/2	150	255	20	20	180	100	220	140
Ø125	140	80	M70X2	80	35	20	78	50	109	1/2	160	295	24	30	222	122	280	170

* The above parameters can be adjusted by special order

* پارامترهای فوق با سفارش خاص قابل تغییر می باشد.

NOVIN HYDRAULIC

TYPE : NHO

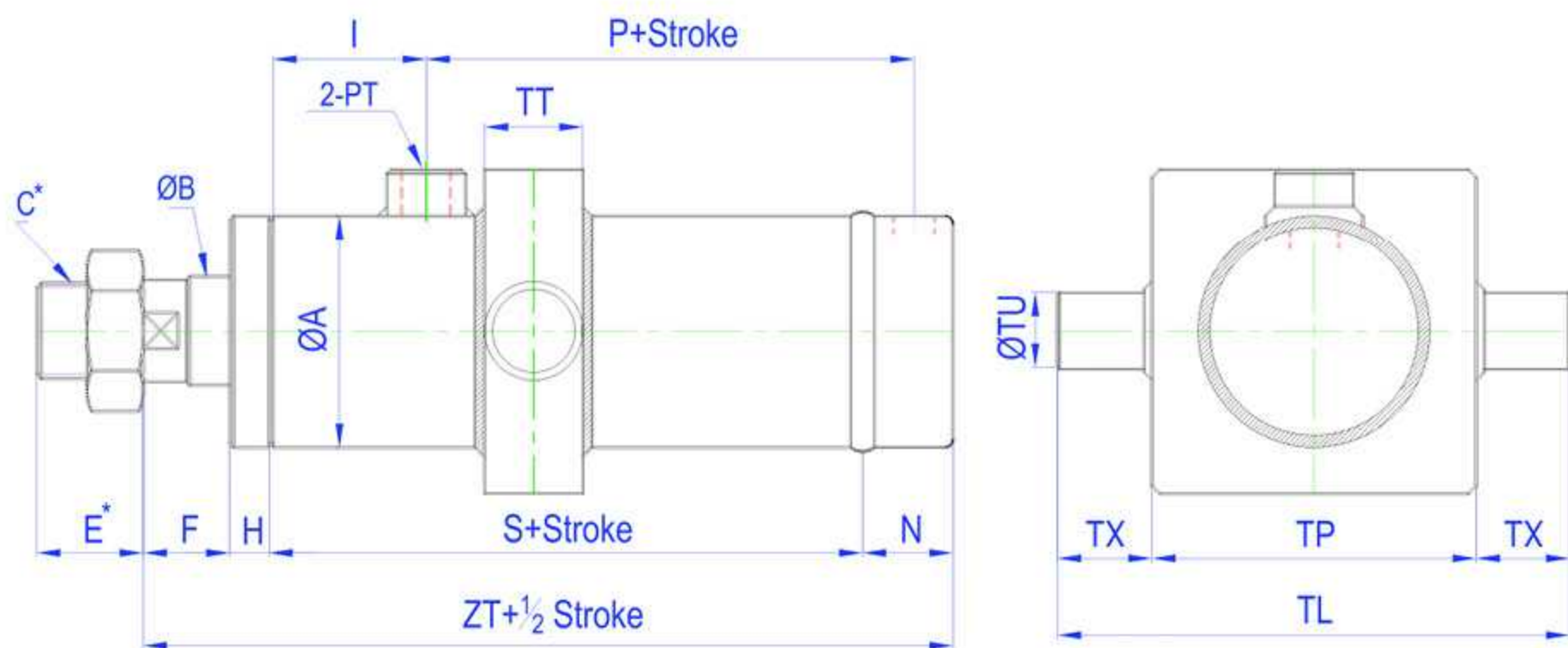

SIZE BORE	ØA	ØB	C*	E*	F*	H	I	N	P	PT	S	ØTU	TP	TL	TT	TX
Ø50	60	35	M30X1.5	40	20	10	56	30	71	3/8	110	25	90	140	33	25
Ø63	73	40	M30X1.5	45	25	10	56	35	79	3/8	115	32	102	166	40	32
Ø80	95	50	M40X2	55	25	15	64	40	83	3/8	125	32	120	184	43	32
Ø100	115	60	M50X2	70	25	20	78	40	94	1/2	150	40	140	220	53	40
Ø125	140	80	M70X2	80	35	20	78	50	109	1/2	160	50	175	275	58	50

* The above parameters can be adjusted by special order

* پارامترهای فوق با سفارش خاص قابل تغییر می باشد.

NOVIN HYDRAULIC

TYPE : NHP

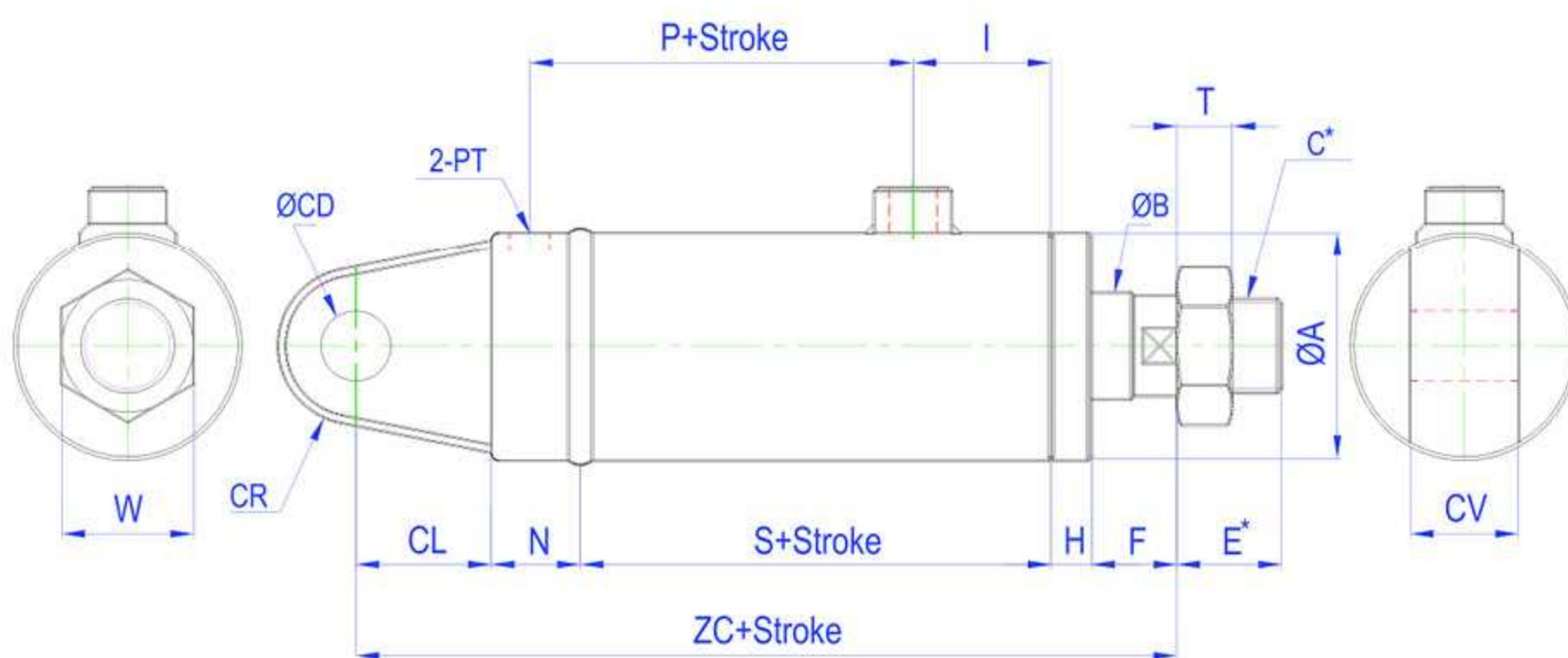

SIZE BORE	ØA	ØB	C*	E*	F*	H	I	N	P	PT	S	W	ZC	ØCD	CL	CV	CR
Ø50	60	35	M30X1.5	40	20	10	56	30	71	3/8	110	35	205	25	35	25	25
Ø63	73	40	M30X1.5	45	25	10	56	35	79	3/8	115	41	230	30	45	30	30
Ø80	95	50	M40X2	55	25	15	64	40	83	3/8	125	41	255	30	50	35	30
Ø100	115	60	M50X2	70	25	20	78	40	94	1/2	150	55	295	35	60	40	35
Ø125	140	80	M70X2	80	35	20	78	50	109	1/2	160	65	335	50	70	55	50

* The above parameters can be adjusted by special order

* پارامترهای فوق با سفارش خاص قابل تغییر می باشد.

NOVIN HYDRAULIC

TYPE : NHQ

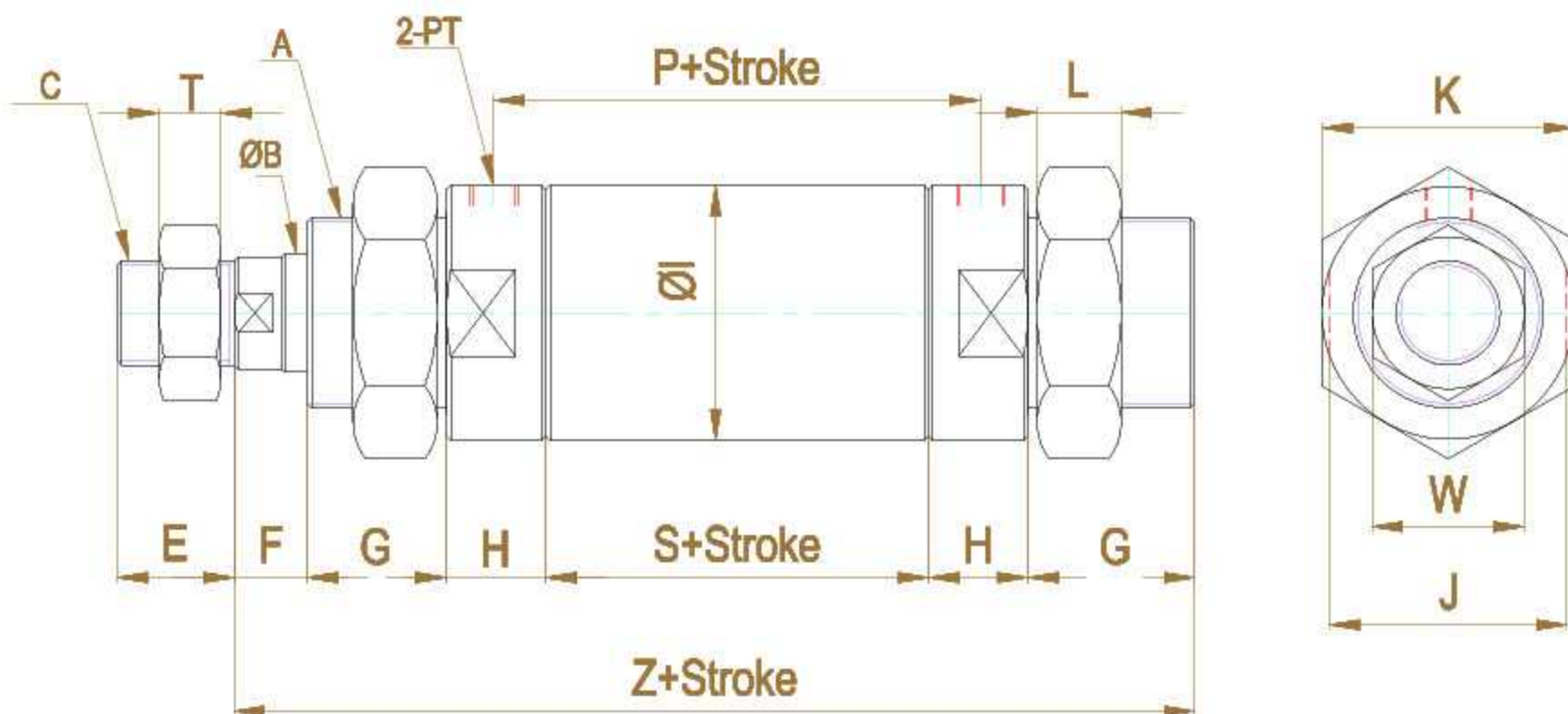

SIZE BORE	A	ØB	C*	E*	F*	G	H	ØI	J	K	L	P	S	PT	W	T	Z
Ø20	M26xP1.5	12	M10xP1.25	25	12	25	15	32	27	35	13	69	54	1/8	16	8	146
Ø30	M30xP1.5	16	M14xP1.5	28	13	25	21	41	37	41	13	83	62	1/4	22	8	167
Ø40	M40xP2.0	20	M16xP1.5	28	17	25	25	50	47	55	15	87	62	3/8	23.5	8	179

* The above parameters can be adjusted by special order

* پارامترهای فوق با سفارش خاص قابل تغییر می باشد.

NOVIN HYDRAULIC

TYPE : NHR

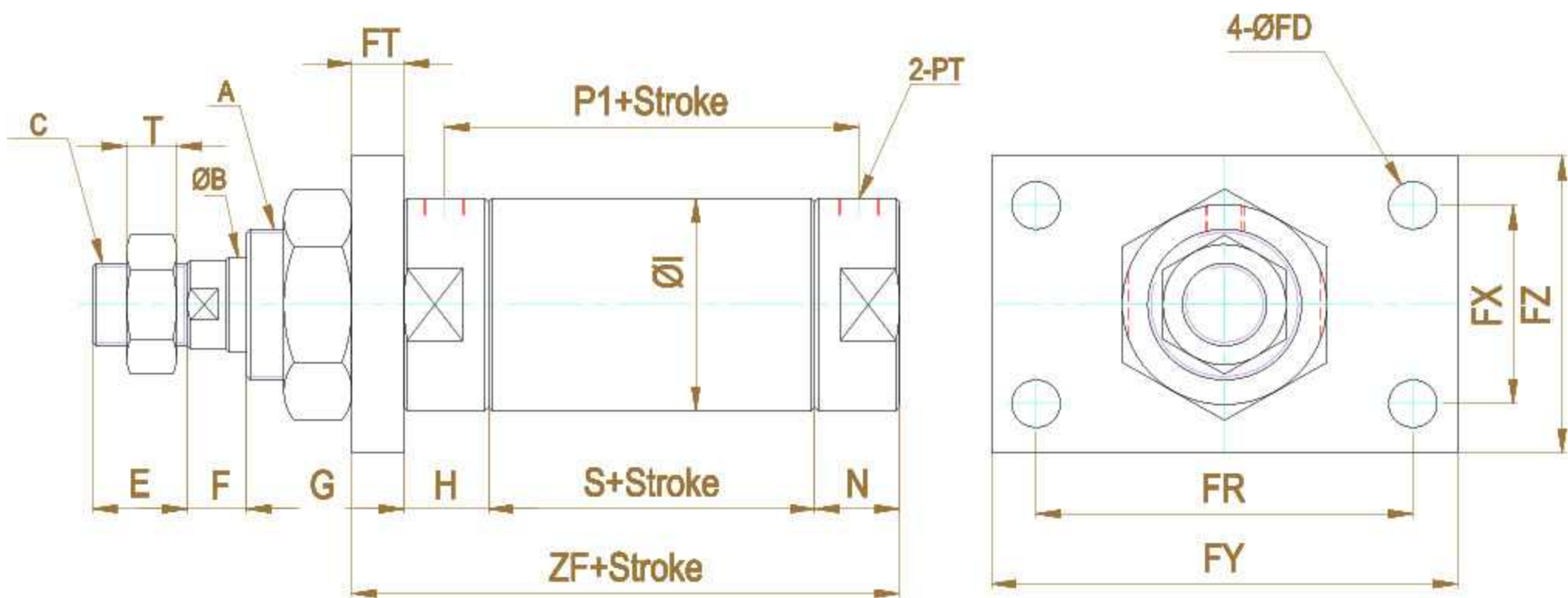

SIZE BORE	A	ØB	C*	E*	F*	G	H	ØI	N	P1	PT	S	T	ZF	ØFD	FT	FR	FX	FY	FZ
Ø20	M26xP1.5	12	M10xP1.25	25	12	25	15	32	18	69	1/8	54	8	96	9	9	56	30	80	45
Ø30	M30xP1.5	16	M14xP1.5	28	13	25	21	41	24	83	1/4	62	8	116	9	9	80	34	105	50
Ø40	M40xP2.0	20	M16xP1.5	28	17	25	25	50	25	87	3/8	62	8	123	12	11	93	50	115	72

* The above parameters can be adjusted by special order

* پارامترهای فوق با سفارش خاص قابل تغییر می باشد.

NOVIN HYDRAULIC

TYPE : NHS

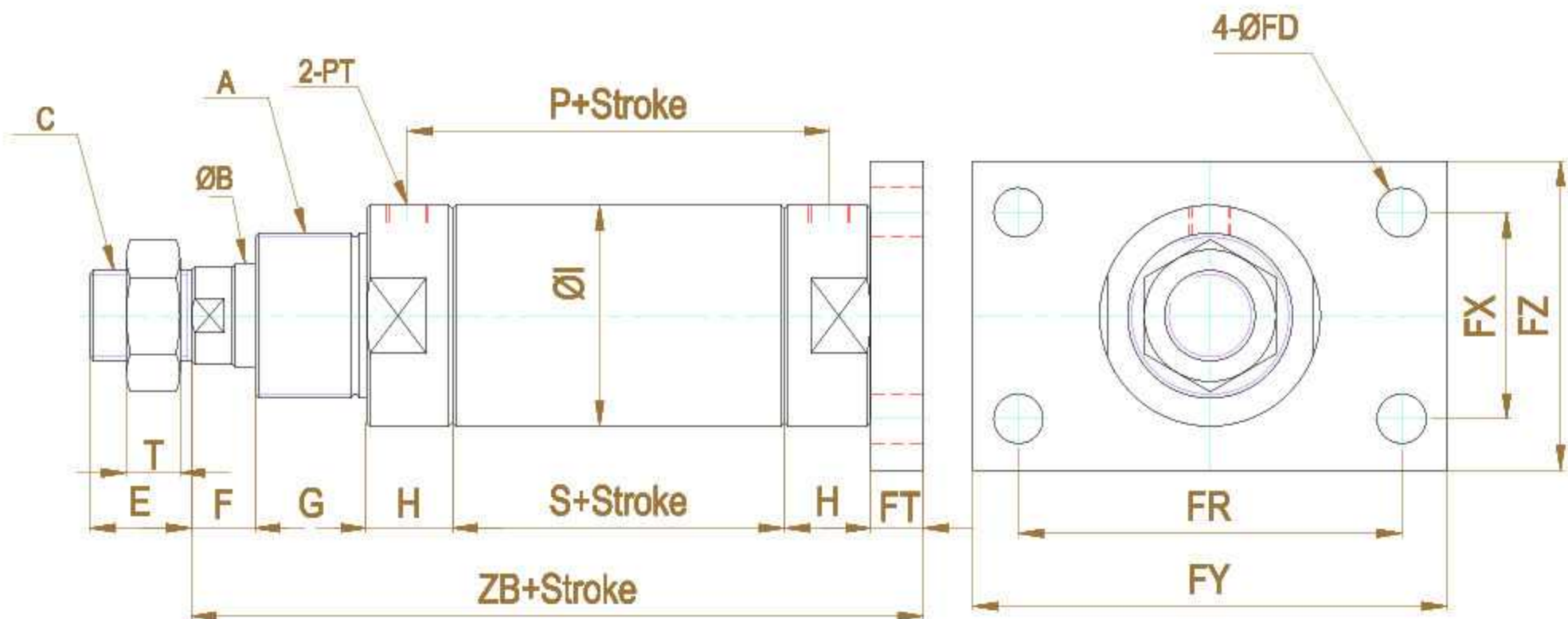

SIZE BORE	A	ØB	C*	E*	F*	G	H	ØI	P	PT	S	T	ZB	ØFD	FT	FR	FX	FY	FZ
Ø20	M26xP1.5	12	M10xP1.25	25	12	25	15	32	69	1/8	54	8	130	9	9	56	30	80	45
Ø30	M30xP1.5	16	M14xP1.5	28	13	25	21	41	83	1/4	62	8	151	9	9	80	34	105	50
Ø40	M40xP2.0	20	M16xP1.5	28	17	25	25	50	87	3/8	62	8	165	12	11	93	50	115	72

* The above parameters can be adjusted by special order

* پارامترهای فوق با سفارش خاص قابل تغییر می باشد.

NOVIN HYDRAULIC

TYPE : NHT

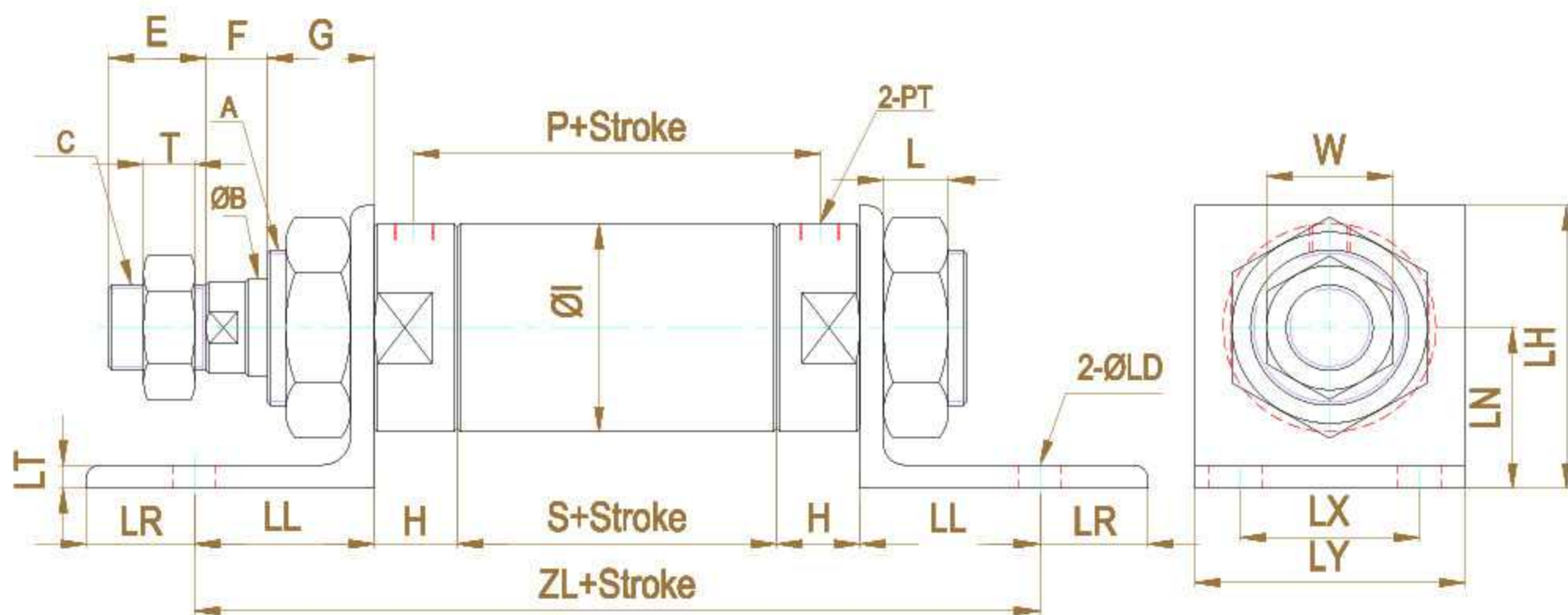

SIZE BORE	A	ØB	C*	E*	F*	G	H	ØI	L	P	PT	S	W	T	ZL	ØLD	LH	LN	LL	LR	LT	LX	LY
Ø20	M26xP1.5	12	M10xP1.25	25	12	25	15	32	13	69	1/8	54	16	8	123	7	55	35	19.5	10.5	4.5	40	55
Ø30	M30xP1.5	16	M14xP1.5	28	13	25	21	41	13	83	1/4	62	22	8	186	10	65	37	41	24	6	50	75
Ø40	M40xP2.0	20	M16xP1.5	28	17	25	25	50	15	87	3/8	62	23.5	8	202	12	75	47	45	30	9	60	88

* The above parameters can be adjusted by special order

* پارامترهای فوق با سفارش خاص قابل تغییر می باشد.

NOVIN HYDRAULIC

TYPE : NHU

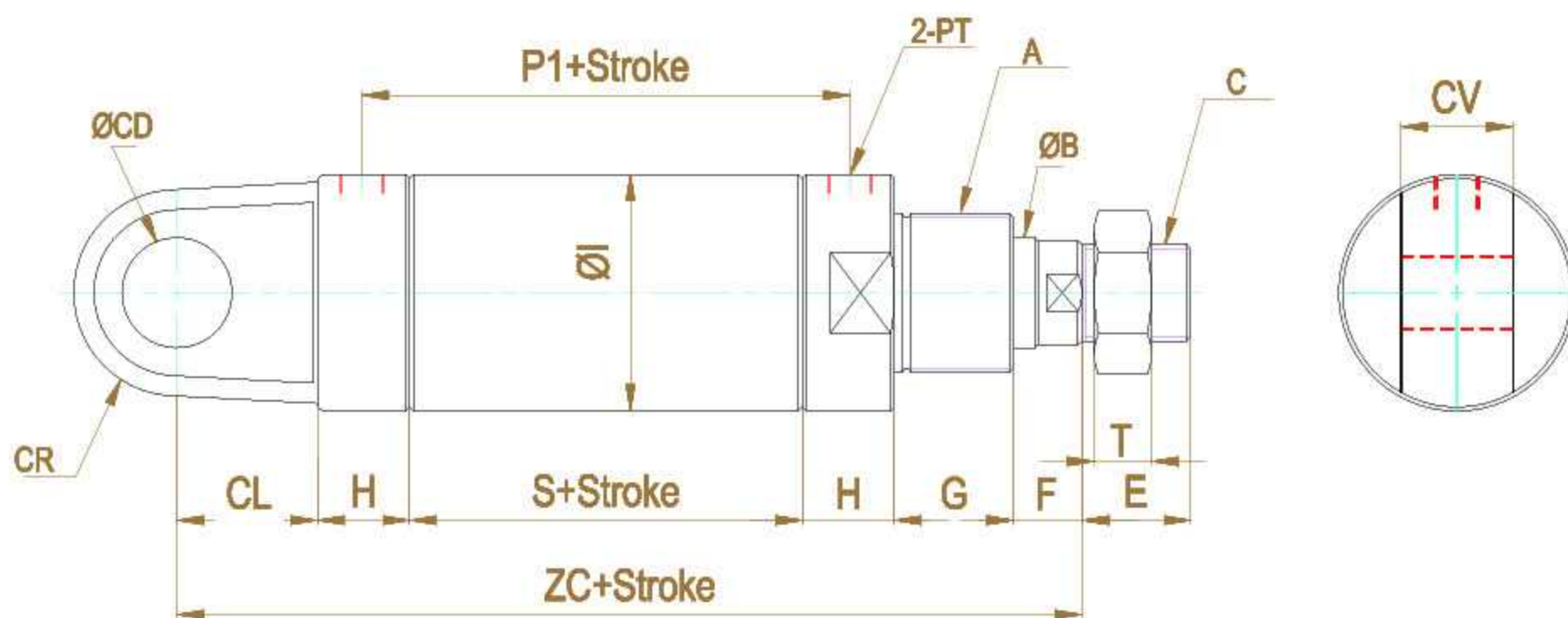

SIZE BORE	A	ØB	C*	E*	F*	G	H	ØI	P	P1	PT	S	T	ZC	ØCD	CL	CR	CV
Ø20	M26xP1.5	12	M10xP1.25	25	12	25	15	32	70.5	69	1/8	54	8	136	10	15	10	15
Ø30	M30xP1.5	16	M14xP1.5	28	13	25	21	41	84.5	83	1/4	62	8	162	16	20	17	23
Ø40	M40xP2.0	20	M16xP1.5	28	17	25	25	50	89.5	87	3/8	62	8	179	16	25	18	25

* The above parameters can be adjusted by special order

* پارامترهای فوق با سفارش خاص قابل تغییر می باشد.



NOVIN HYDRAULIC

TYPE : NHW

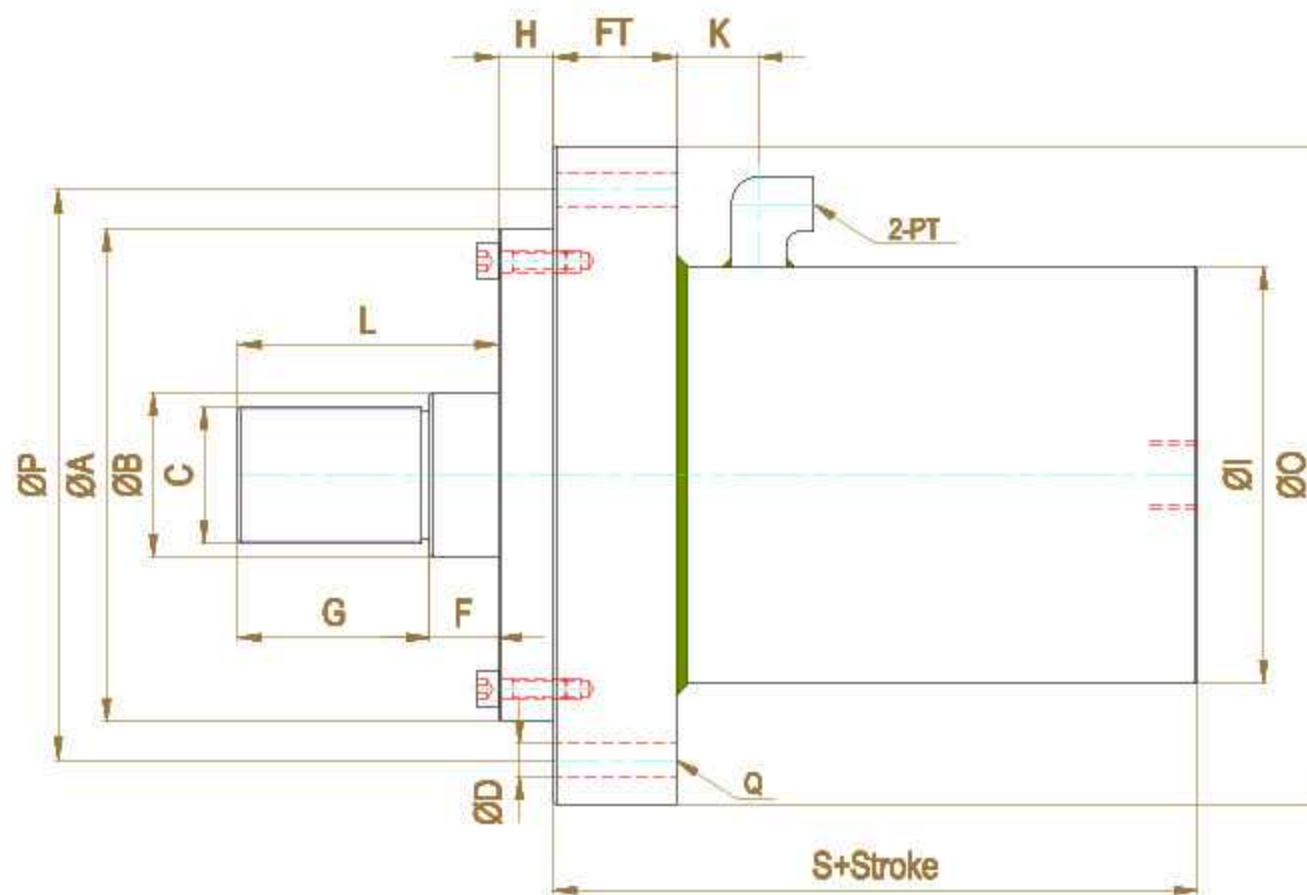

SIZE BORE	ØA	ØB	C*	F*	G*	L	FT	H	ØI	K	O	ØP	PT	Q	ØD	S
Ø125	180	60	M50xP2	25	70	95	45	20	152	30	240	210	3/4	6	18	190
Ø150	205	80	M70xP2	25	80	105	50	20	175	30	280	240	1	6	18	200
Ø180	245	100	M90xP2	30	100	130	60	30	216	30	320	280	1	6	18	230
Ø200	265	120	M100xP2	30	120	150	65	30	242	35	350	310	1.1/4	6	20	250
Ø225	295	140	M120xP3	30	140	170	70	35	270	35	380	340	1.1/4	8	20	260
Ø250	335	160	M140xP3	30	150	180	75	35	298	40	440	380	1.1/4	8	24	275
Ø280	365	180	M160xP4	30	160	190	80	40	330	40	500	430	1.1/2	10	26	290
Ø300	385	200	M180xP4	35	160	195	85	40	350	45	550	460	1.1/2	10	28	320

* The above parameters can be adjusted by special order

* پارامترهای فوق با سفارش خاص قابل تغییر می باشد.

NOVIN HYDRAULIC

TYPE : NHY

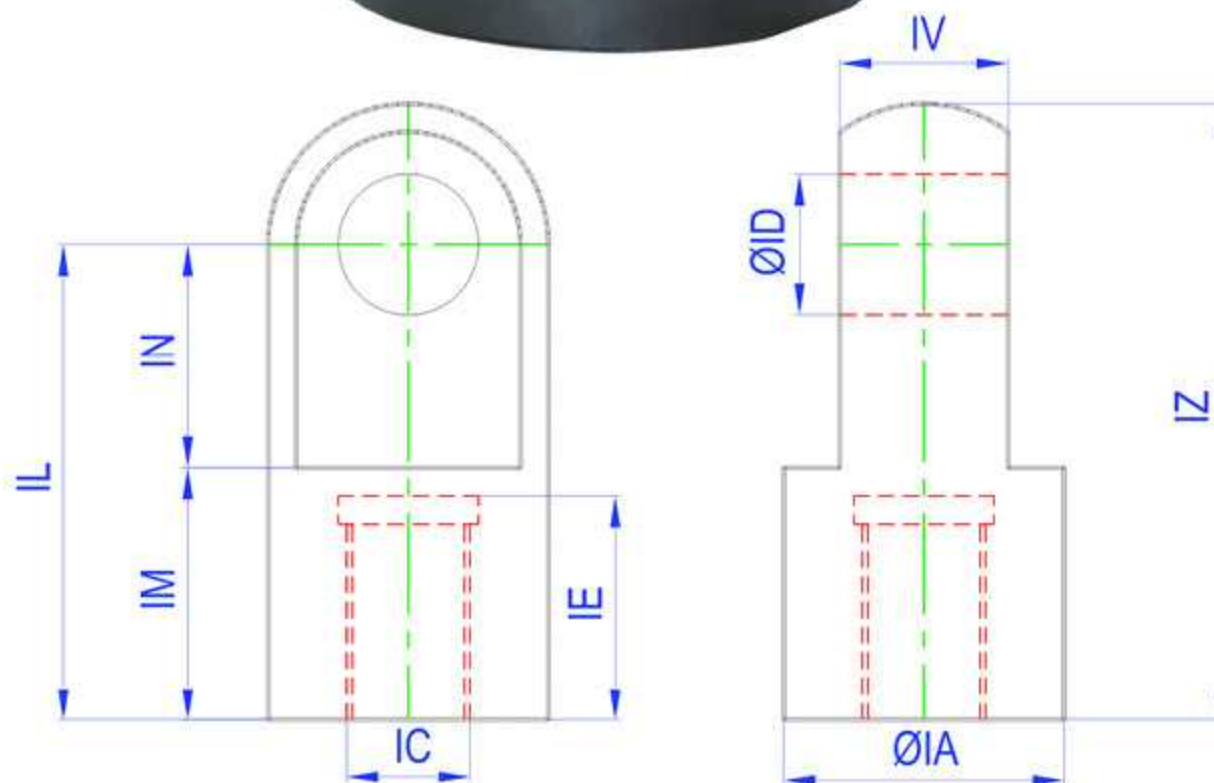

Rod EYE		Material : St 52							
TYPE	IA	IC	ØID	IE	IL	IM	IN	IV	IZ
NHY 1	40	M22XP1.5	20	25	57	36	21	22	80
NHY 2	50	M26XP1.5	25	40	85	45	40	30	110
NHY 3	55	M30XP1.5	25	40	83	45	38	35	110
NHY 4	75	M40XP2	35	50	90	40	50	45	130
NHY 5	90	M50XP2	50	60	105	50	55	55	150
NHY 6	115	M70XP2	60	65	120	65	55	60	177
NHY 7	150	M90XP2	70	82	180	90	90	70	250

NOVIN HYDRAULIC

TYPE : NHZ

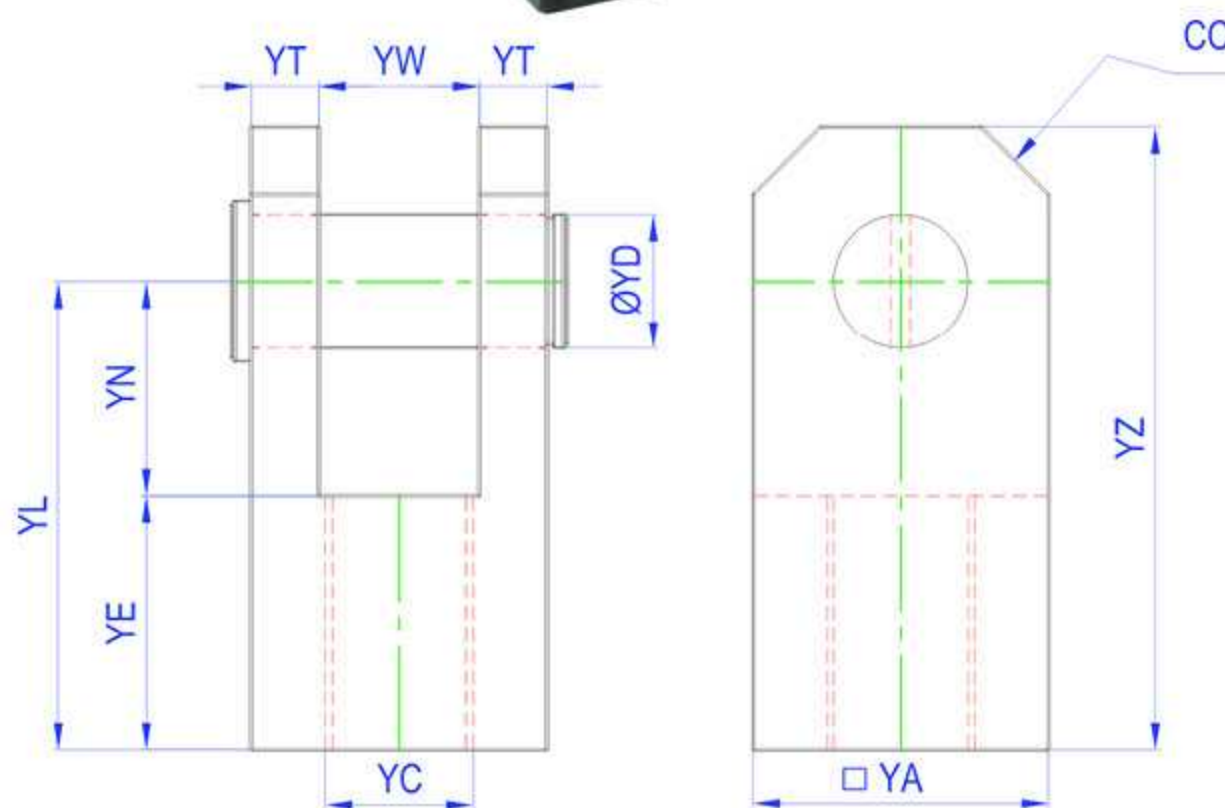

Female Fork			Material : St 52							
TYPE	YA	YC	YD	YE	YN	YT	YL	YW	YZ	CC
NHZ 1	44	M22XP1.5	20	38	32	10	70	24	93	10
NHZ 2	50	M26XP1.5	20	37	33	11.5	70	27	96	10
NHZ 3	60	M30XP1.5	30	40	48	15	88	30	115	10
NHZ 4	70	M40XP2	35	47	46	20	93	30	127	15
NHZ 5	80	M50XP2	40	50	50	22.5	100	35	140	15
NHZ 6	115	M70XP2	50	60	60	27.5	120	60	170	25
NHZ 7	150	M90XP2	70	85	85	40	170	70	240	30

NOVIN HYDRAULIC

HYDRAULIC CYLINDERS

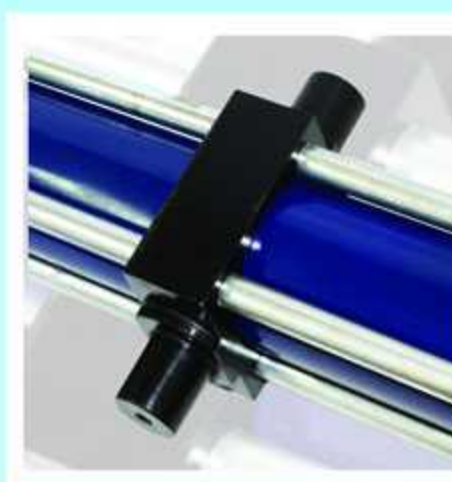
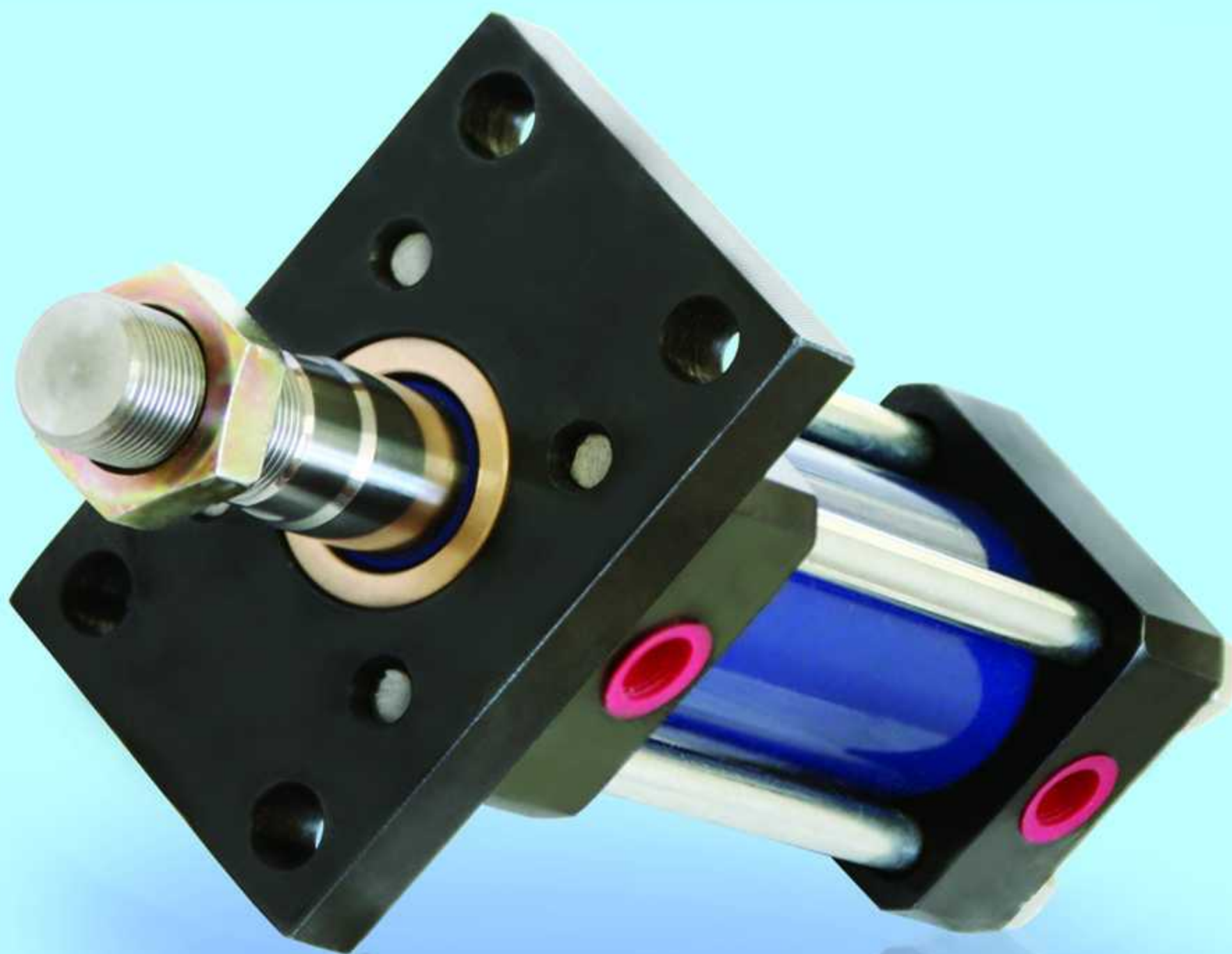

نشانی: تهران، شادآباد، انتهای خیابان هفده شهریور، خیابان جوشن، کوچه ششم غربی، پلاک ۴ هیدرولیک پنوماتیک نوین

تلفن: ۹-۶۶۷۸۵۴۷۸ (۰۲۱) نمابر: ۶۶۶۴۸۸۲۰ (۰۲۱)

Novin hydraulic, No 4, Sixth Street West, Joshan St, at the end of 17 Shahrivar St, Shadabad, Tehran, Iran

Tel : (+98) 21 66785478-9 Fax : (+98) 21 66648820

Email : info@novinhydraulic.com